



LQ-Integration Laser plastics welding system for full integration into production lines

- Compact welding head with separate control cabinet
- Simple integration with comprehensive automation interfaces
- Highest process reliability and safety with integrated process control
- Versatile software and clamping technology

LQ-Integration Laser welding system featuring full integration into production lines

- Application change in less than ten minutes using standardized adapter
- Ultra short cycle times
- Designed for automatic operation

The LQ-Integration series features advanced plastics welding technology for seamless integration with production lines. LPKF's in-depth process expertise and many years of experience in mechanical engineering and automation technology makes this integration possible. LQ-Integration systems fully comply with the most stringent industrial specifications and meet or exceed the highest quality standard requirements.

LQ-Integration welds components as large as 210 x 210 mm. The welding system is designed for integration in a work carrier system or a rotary indexing table, and can be used for contour-based as well as scanner-based welding. It forms a complete system when combined with a work carrier, and offers the highest level of quality and safety due to the 100% integrated control system.

The basic system is completely customizable with optional accessories. Modular construction permits simple and cost-effective adjustment of the system to any type of application by selecting the optimum laser power and optical components. The clamping device is fast and efficient, perfect for a wide range of different components.

Because the control cabinet can be installed in a separate location from the integrated welding head, LQ-Integration systems easily fit into a pre-existing assembly setup. Comprehensive automation interfaces complete the task.



Automotive tyre pressure sensor



Shaver casing



Automotive clutch sensor



Interfaces

- Hardware (mechanical)
- Software
- Control interface
- Process data recording interface (optional)

Integration examples

- Installation on work carrier (see left side) or rotary indexing table system (see above).
- Compact installation

System components

- Fiber-optic diode laser
- Custom optics configuration available
- Galvanometer scanner
- "Dual Clamp Device" option available
- Protective housing

LaserEquipment® embodies the highest quality standards

Complete software support

- Intuitive menu-driven software behind a simple touch-screen
- Fully programmable
- Easy-to-set parameters
- Integrated online process control
- Available with Siemens touch panel PC

Simple process setup

- ProSet: Intuitive software for simple "teach-in" of new welding contours
- Pilot laser for easy welding contour adjustment directly on the workpiece

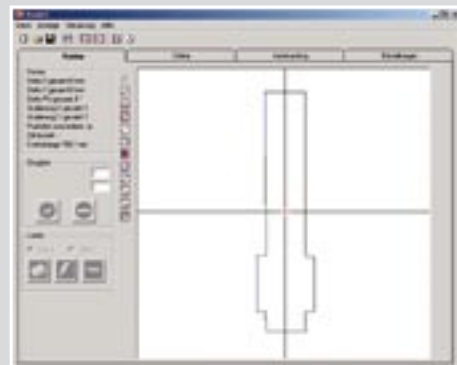

Maximum machine uptime

- Siemens PLC components assure trouble-free operation
- High quality components by leading manufacturers
- Rugged engineering
- Designed for constant three-shift-production
- Mass production (> 10 million parts/year)
- Low-maintenance

Easy maintenance

- All components integrated within the control cabinet
- All machine modules fully accessible
- No external cooling system needed
- Plug & Play modul

Advanced safety and ergonomics

- Class I laser (combined with a suitable work carrier)
- Certified to Class IV safety standards
- Laser protection fully adjustable
- CE machine certification

Technical specifications LQ-Integration	
Laser beam source	Water-cooled fiber-coupled diode laser Wavelength: 980 nm (also available as 808 nm, 915 nm, or 940 nm) Laser power: 30–210 W (high power option up to 400 W) Fiber optic: 0.3 mm diameter (other diameters optional) Fiber optic with integrated connection, breakage, and temperature monitoring
Beam guide	Galvanometer scanner – aperture 20 mm (or 30 mm)
Working field	45 x 45 mm (1.8" x 1.8"), 110 x 110 mm (4.3" x 4.3"), 154 x 154 mm (6.1" x 6.1")
Clamping technology	Pneumatic top-down clamping Electronic supervision of end positions Inductive measurement system to record the welding process Adapter plates for a variety of clamping tools
System control	Siemens 315 F failsafe CPU Siemens TP 170B touch panel controls Parameter management Industrial PC for process data archiving (optional)
Software	LPKF ProSeT software for programming the welding path
Online process monitoring	Process monitoring with: time control, process control, speed control
Interfaces	24 V control I/O lines, Ethernet, RS-232, PROFIBUS, Anybus
Power requirements	Voltage: 400 V/16 A (Germany, others available) Current: max. 3 kW Air supply: 6 bar dry air
Environmental conditions	Maximum operating temperature: 40 °C (104 °F) Maximum humidity: 80% at 25 °C (77 °F)
Cooling system	Integrated water/air cooling unit Integrated water heat exchanger (optional)
Options	Clamping tool encoding Air-cooled clamping tools (patent pending) Advanced burn detection (patent pending) Remote maintenance option
Dimensions (W/H/D)	
Control cabinet	800 x 800 x 2,000 mm (31.5" x 31.5" x 78.7")
Welding unit	400 x 700 x 650 mm (15.7" x 27.6" x 25.6")

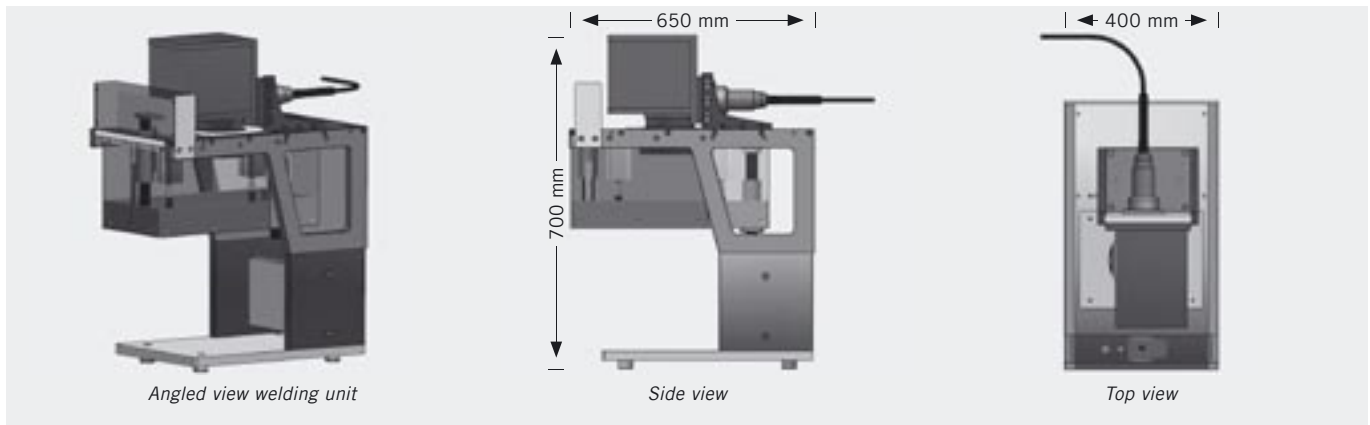

This machine is designed as a Class I Laser Product.

LPKF Laser & Electronics AG
Plastics Welding Division
Gundstraße 15
D-91056 Erlangen
Germany

Phone +49 (0) 91 31-6 16 57-10
Fax +49 (0) 91 31-6 16 57-77

info@laserequipment.de
www.laserequipment.com

LPKF-Distributor